

> MATERIAL:

303 Stainless Steel

PHONE: 516.328.3300 • FAX: 516.326.8827 • WWW.SDP-SI.COM

Available on special order:
Hubs assembled to gears or
dials, and passivation.

Fairloc® hubs require controlled
shaft tolerances. Suggested clearance
fit between the bore and the shaft is .0001/.0008.

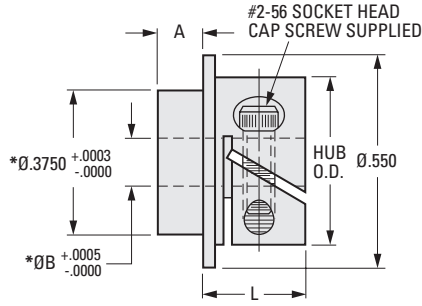
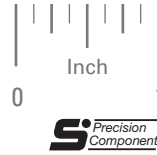

*Diameters Concentric within .0003 T.I.R

INCH COMPONENT

Catalog Number	A	B Bore	L	Hub O.D.	Cap Screw Clearance Radius
S2F06Y-062090	.062	.0900	.265	.437	.273
S2F06Y-125090	.125	.0900	.265	.437	.273
S2F06Y-062094	.062	.0937	.265	.437	.273
S2F06Y-125094	.125	.0937	.265	.437	.273
S2F06Y-062120	.062	.1200	.265	.437	.273
S2F06Y-125120	.125	.1200	.265	.437	.273
S2F06Y-062125	.062	.1248	.265	.437	.273
S2F06Y-125125	.125	.1248	.265	.437	.273
S2F06Y-062187	.062	.1873	.265	.437	.273
S2F06Y-125187	.125	.1873	.265	.437	.273
S2F06Y-187187	.187	.1873	.265	.437	.273
S2F06Y-062241	.062	.2405	.295	.530	.304
S2F06Y-125241	.125	.2405	.295	.530	.304
S2F06Y-187241	.187	.2405	.295	.530	.304
S2F06Y-062250	.062	.2498	.295	.530	.304
S2F06Y-125250	.125	.2498	.295	.530	.304
S2F06Y-187250	.187	.2498	.295	.530	.304