

Specifications	
Precision grade	JIS grade N9 (JIS B1702-1: 1998)*
Gear teeth	Standard full depth
Pressure angle	20°
Material	MC901
Heat Treatment	—
Tooth hardness	(115 to 120HRR)

* The precision grade of J Series products is equivalent to the value shown in the table.

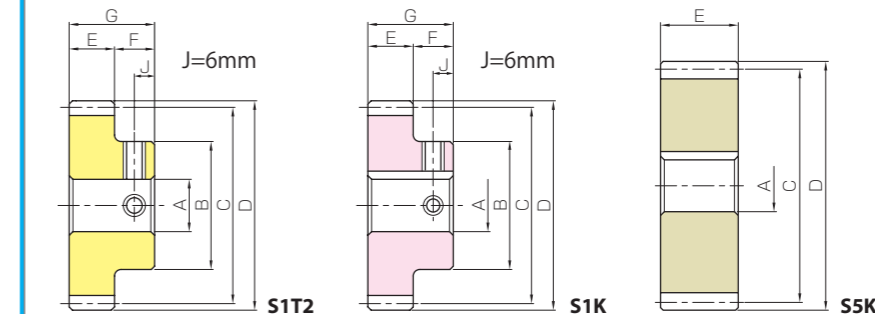
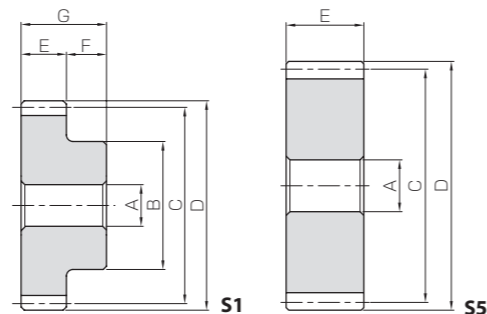

Catalog Number	No. of teeth	Shape	Bore		Pitch dia.			Hub width	Total Length	Allowable torque (N·m)	Allowable torque (kgf·m)	Backlash (mm)	Weight (kg)												
			A	B	C	D	E							F											
KPS2.5-12	12	S1	10	23	30	35	12	37	4.39	0.45	0~0.44	0.023													
KPS2.5-13	13			25	32.5	37.5							5.06	0.52											
KPS2.5-14	14			25	35	40									5.77	0.59									
KPS2.5-15	15			30	37.5	42.5											6.42	0.65							
KPS2.5-16	16			32	40	45													7.09	0.72					
KPS2.5-18	18			38	45	50															8.28	0.84			
KPS2.5-20	20		40	50	55	9.59	0.98																		
KPS2.5-22	22		44	55	60			10.8	1.11																
KPS2.5-24	24		48	60	65					12.1	1.23														
KPS2.5-25	25		50	62.5	67.5							12.8	1.30												
KPS2.5-26	26		12	15	55									65	70	13.5	1.37								
KPS2.5-28	28				60									70	75			14.7	1.50						
KPS2.5-30	30				65	75	80							16.0	1.63										
KPSA2.5-32	32				S5	15	80	85	25											37	17.4	1.77			
KPSA2.5-35	35						87.5	92.5		19.5	1.99														
KPSA2.5-36	36						90	95				20.3	2.07												
KPSA2.5-40	40	100	105	23.2			2.36																		
KPSA2.5-45	45	112.5	117.5					26.8								2.73									
KPSA2.5-48	48	120	125											29.0	2.96										
KPSA2.5-50	50	125	130														30.6	3.12							
KPSA2.5-55	55	137.5	142.5																34.1				3.48		
KPSA2.5-60	60	150	155																					37.7	3.84

- [Caution on Product Characteristics]
- Significant variations in temperature or humidity can cause dimensional changes in plastic gears, including bore size (H8 when produced), tooth diameter, and backlash. Please see the section "Design of Plastic Gears" in our separate technical reference book. (Page 100).
 - The allowable torques shown in the table are calculated values according to the assumed usage conditions. Please see Page 24 for more details.
 - Without lubrication, using plastic gears in pairs may generate heat and dilation. It is recommended to mate them with steel gears.
 - The backlash values shown in the table are the theoretical values for the backlash in the normal direction of a pair of identical gears in mesh.

- [Caution on Secondary Operations]
- Please read "Cautions on Performing Secondary Operations" (Page 26) when performing modifications and/or secondary operations for safety concerns.
 - Plastic gears are susceptible to the effects of temperature and moisture. Dimensional changes may occur while performing secondary operations and during post-machining operations.

* In regard to MC Nylon gears, other materials are available for plastic gears, including Ultra High Molecular Weight Polyethylene (U-PE), which has excellent abrasion resistance and resin conforming to the Plastic Implementation Measure (PIM). A single piece order is acceptable and will be produced as a custom-made gear.

To order J Series products, please specify: **Catalog No. + J + BORE.**

Bore H8	* The product shapes of J Series items are identified by background color.																							
	10	12	14	15	16	17	18	19	20	22	25	28	30	32	35	40	45	50						
Keyway Js9	4x1.8				5x2.3				6x2.8				8x3.3				10x3.3				12x3.3		14x3.8	
Screw size	M4				M5				M6				M8				—							
Catalog Number	—																							
KPS2.5-12 J BORE	S1T2																							
KPS2.5-13 J BORE	S1K																							
KPS2.5-14 J BORE	S1K	S1K																						
KPS2.5-15 J BORE		S1K	S1K																					
KPS2.5-16 J BORE		S1K	S1K	S1K	S1K																			
KPS2.5-18 J BORE		S1K	S1K	S1K	S1K	S1K	S1K	S1K	S1K															
KPS2.5-20 J BORE		S1K	S1K	S1K	S1K	S1K	S1K	S1K	S1K	S1K														
KPS2.5-22 J BORE		S1K	S1K	S1K	S1K	S1K	S1K	S1K	S1K	S1K	S1K													
KPS2.5-24 J BORE		S1K	S1K	S1K	S1K	S1K	S1K	S1K	S1K	S1K	S1K	S1K												
KPS2.5-25 J BORE		S1K	S1K	S1K	S1K	S1K	S1K	S1K	S1K	S1K	S1K	S1K	S1K											
KPS2.5-26 J BORE		S1K	S1K	S1K	S1K	S1K	S1K	S1K	S1K	S1K	S1K	S1K	S1K	S1K										
KPS2.5-28 J BORE		S1K	S1K	S1K	S1K	S1K	S1K	S1K	S1K	S1K	S1K	S1K	S1K	S1K	S1K									
KPS2.5-30 J BORE		S1K	S1K	S1K	S1K	S1K	S1K	S1K	S1K	S1K	S1K	S1K	S1K	S1K	S1K	S1K								
KPSA2.5-32 J BORE				S5K	S5K	S5K	S5K	S5K	S5K	S5K	S5K	S5K	S5K	S5K	S5K	S5K								
KPSA2.5-35 J BORE				S5K	S5K	S5K	S5K	S5K	S5K	S5K	S5K	S5K	S5K	S5K	S5K	S5K	S5K							
KPSA2.5-36 J BORE				S5K	S5K	S5K	S5K	S5K	S5K	S5K	S5K	S5K	S5K	S5K	S5K	S5K	S5K							
KPSA2.5-40 J BORE				S5K	S5K	S5K	S5K	S5K	S5K	S5K	S5K	S5K	S5K	S5K	S5K	S5K	S5K	S5K						
KPSA2.5-45 J BORE				S5K	S5K	S5K	S5K	S5K	S5K	S5K	S5K	S5K	S5K	S5K	S5K	S5K	S5K	S5K						
KPSA2.5-48 J BORE				S5K	S5K	S5K	S5K	S5K	S5K	S5K	S5K	S5K	S5K	S5K	S5K	S5K	S5K	S5K						
KPSA2.5-50 J BORE				S5K	S5K	S5K	S5K	S5K	S5K	S5K	S5K	S5K	S5K	S5K	S5K	S5K	S5K	S5K						
KPSA2.5-55 J BORE				S5K	S5K	S5K	S5K	S5K	S5K	S5K	S5K	S5K	S5K	S5K	S5K	S5K	S5K	S5K						
KPSA2.5-60 J BORE				S5K	S5K	S5K	S5K	S5K	S5K	S5K	S5K	S5K	S5K	S5K	S5K	S5K	S5K	S5K						

- [Caution on J series]
- As available-on-request products, these require a lead-time for shipping within 2 working days (excludes the day ordered), after placing an order.
 - Number of products we can process for one order is 1 to 20 units. For quantities of 21 or more pieces, we need to quote price and lead time.
 - Keyways are made according to JIS B1301 standards, Js9 tolerance. They may be 0.01 mm negative depending on material characteristics.
 - Certain products which would otherwise have a very long tapped hole are counterbored to reduce the length of the tap.
 - For products having a tapped hole, a set screw is included.
 - Since tapped holes of plastic products are easily broken, avoid too much tightening when fastening screws. For products which have a short tapped hole (Products marked with " ** " are the tap size), fasten with torques less than 0.12N·m for M4, and 0.38N·m for M5.
 - When using S1T2 set screws for fastening gears to a shaft, only use this method for applications with light load usage. For secure fastening, please use dowel pins in combination.

Stainless Steel Hubs for KPSA Now Available!
Standardized sectional stainless steel hubs. They create a secure method for fastening to the shaft.

Knockdown style

Please see Page 152 for more details.

How to attach gears to shafts

To attach gears to shafts, in case of light loads, methods include using keys, taper pins, spring pins, and press fitting after mounting the set-screws. Since loosening tends to occur in the conditions below, plastic gears are better fastened by using a steel hub.

- When the circumferential temperature is high
- For large diameter gears
- If forward-reverse motion impacts keys

For fastening steel hubs into plastic gears with bolts, see right for various methods.

Fastening with a steel hub bolt