

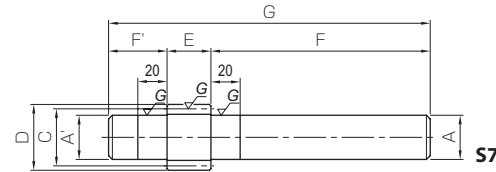

Specifications	
Precision grade	JIS grade N7 (JIS B1702-1:1998)
Gear teeth	Standard full depth
Pressure angle	20°
Material	S45C
Heat Treatment	Thermal refined, gear teeth induction hardened
Tooth hardness	50 to 60HRC
Surface treatment	Black oxide coated except for ground part



Catalog Number	Module	No. of teeth	Dislocation coefficient	Shape	Shaft dia. (L)		Pitch dia.	Outside dia.	Face width	Shaft dia. (R)		Total Length
					A'	F'				A	F	
KSSGS1.5-10	m1.5	10	+0.5	S7	12.2	25	15	19.35	15	12.2	100	140
KSSGS1.5-11		11	+0.5		13.7		20.85	13.7				
KSSGS1.5-12		12	0		13.7		21	13.7				
KSSGS1.5-13		13	0		15.2		22.5	15.2				
KSSGS2-10	m2	10	+0.5	S7	16.2	30	20	25.8	20	16.2	120	170
KSSGS2-11		11	+0.5		18.2		27.8	18.2				
KSSGS2-12		12	0		18.2		28	18.2				
KSSGS2-13		13	0		20.2		30	20.2				
KSSGS2.5-10	m2.5	10	+0.5	S7	20.2	35	25	32.25	25	20.2	135	195
KSSGS2.5-11		11	+0.5		22.7		34.75	22.7				
KSSGS2.5-12		12	0		22.7		35	22.7				
KSSGS2.5-13		13	0		25.2		37.5	25.2				
KSSGS3-10	m3	10	+0.5	S7	24.2	40	30	38.7	30	24.2	150	220
KSSGS3-11		11	+0.5		27.2		41.7	27.2				
KSSGS3-12		12	0		27.2		42	27.2				
KSSGS3-13		13	0		30.2		45	30.2				

[Caution on Product Characteristics] The allowable torques shown in the table are calculated values according to the assumed usage conditions. Please see Page 24 for more details.
 Products with modules 1.5 or higher and number of teeth of 10 and 11 are profile shifted gears ($x = +0.5$). Please refer to the table below for the center distance at the time of assembly.
 The indicated backlash is the backlash in the normal direction when a 30-tooth KSSG spur gear is assembled with the same module using theoretical values.

Allowable torque (N·m)		Allowable torque (kgf·m)		Backlash (mm)	Weight (kg)	Catalog Number
Bending strength	Surface durability	Bending strength	Surface durability			
12.7	3.76	1.30	0.38	0.08~0.16	0.14	KSSGS1.5-10
14.5	4.61	1.48	0.47			
9.97	4.70	1.02	0.48			
12.1	5.51	1.23	0.56			
30.2	9.07	3.08	0.93	0.11~0.21	0.30	KSSGS2-10
34.3	11.0	3.50	1.12			
23.6	11.3	2.41	1.15			
28.6	13.3	2.92	1.35			
58.9	17.9	6.01	1.83	0.11~0.21	0.54	KSSGS2.5-10
67.1	22.0	6.84	2.24			
46.2	22.4	4.71	2.28			
46.6	21.9	4.75	2.23			
102	31.3	10.4	3.19	0.11~0.21	0.89	KSSGS3-10
96.6	31.9	9.85	3.26			
66.5	32.6	6.78	3.32			
80.4	38.3	8.20	3.91			

[Caution on Secondary Operations] Please read "Cautions on Performing Secondary Operations" (Page 26) when performing modifications and/or secondary operations for safety concerns.
 Due to the gear teeth being induction hardened, no secondary operations can be performed on tooth areas including the bottom land (approx. 2 to 3 mm). Please use a carbide tool or the like when machining shafts that are close to the tooth root.

Center distance of stock spur gear meshing with profile shifted gear

The center distance of the stock gear ($x = 0$) that meshes with profile shifted gear ($x = +0.5$) of $m = 1$ is shown in the table at right. Please multiply the module of the gear to be used.

No. of teeth ($x = 0$)	No. of teeth ($x = +0.5$)	10	11
12	11.4410	11.9428	
13	11.9428	12.4446	
14	12.4446	12.9462	
15	12.9462	13.4477	
16	13.4477	13.9492	
17	13.9492	14.4505	
18	14.4505	14.9518	
19	14.9518	15.4530	
20	15.4530	15.9542	
21	15.9542	16.4553	
22	16.4553	16.9564	
23	16.9564	17.4574	
24	17.4574	17.9583	
25	17.9583	18.4592	
26	18.4592	18.9601	
27	18.9601	19.4610	
28	19.4610	19.9618	
29	19.9618	20.4625	
30	20.4625	20.9633	

No. of teeth ($x = 0$)	No. of teeth ($x = +0.5$)	10	11
32	21.4640	21.9647	
34	22.4653	22.9660	
35	22.9660	23.4666	
36	23.4666	23.9671	
38	24.4677	24.9683	
40	25.4688	25.9693	
42	26.4698	26.9703	
44	27.4707	27.9712	
45	27.9712	28.4716	
46	28.4716	28.9721	
48	29.4725	29.9729	
50	30.4733	30.9736	
52	31.4740	31.9744	
54	32.4747	32.9750	
55	32.9750	33.4754	
56	33.4754	33.9757	
58	34.4760	34.9763	
60	35.4766	35.9769	
62	36.4772	36.9774	

No. of teeth ($x = 0$)	No. of teeth ($x = +0.5$)	10	11
64	37.4777	37.9780	
65	37.9780	38.4782	
66	38.4782	38.9785	
68	39.4787	39.9790	
70	40.4792	40.9794	
72	41.4796	41.9799	
75	42.9803	43.4805	
76	43.4805	43.9807	
80	45.4813	45.9814	
84	47.4820	47.9822	
85	47.9822	48.4823	
88	49.4826	49.9828	
90	50.4830	50.9831	
95	52.9837	53.4838	
100	55.4844	55.9845	
120	65.4866	65.9867	
150	80.4890	80.9890	
200	105.4915	105.9915	

Mounting distance of a profile shifted gear and the meshing rack

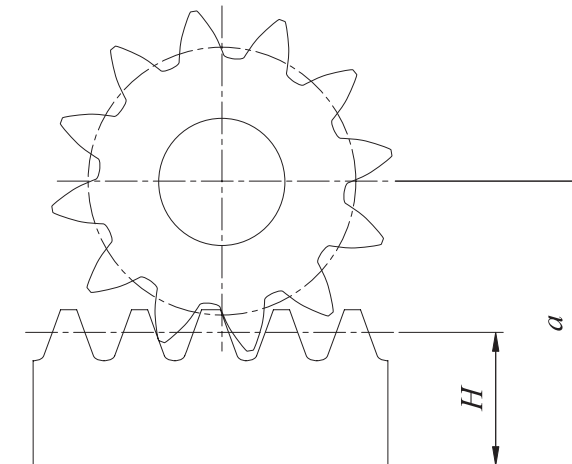

$$a = \frac{zm}{2} + H + xm$$

Where
 a : Mounting distance
 H : Pitch line height
 m : Module
 z : No. of teeth
 x : Dislocation coefficient

